

PHASERAISER®

U.S. PATENT NOs. 6,115,988 6,151,860 CANADIAN PATENT NOs. 2,252,115 2,297,318

PRH UNITS



Installation Guidelines for PhaseRaiser® PRH, Non-Driven Units

- H-Frame Structures •

LWS

Laminated Wood Systems, Inc.

PhaseRaiser® Installation & Tool Equipment Guidelines

Basic PhaseRaiser Procedures

The PhaseRaiser® Structure Lifting System is designed to allow a six person crew to increase the height of a an existing structure up to an additional 5', 10', 15' or 20' to solve NESC or NERC clearance points of interest. It is an option the utility may use when the existing structures are structurally sound and are determined to have adequate remaining service life.

The crew will typically consist of six workers; four working aloft either on steel working ladders or in an aerial lift device, and two workers on the ground attending to the workers in the air. The entire crew does not need to be Journeymen, and can have apprentices or lower rated individuals in the crew given qualified leadership. The work can, and is, done with the line energized. Initial lifts are done with the guidance of an LWS field trainer.

The PhaseRaiser PRH system is designed to lift only tangent, H-frame type structures.

NO GUYED STRUCTURE SHALL BE LIFTED UNLESS LWS ENGINEERS HAVE DETERMINED THAT THE GUYS ARE NOT STRUCTURAL.

The contractor must check with the utility for conformance to all applicable safety and operating requirements to include personal protective equip-

ment, fall protection, equipment grounding and electrical switching requirements.

The contractor must check with the utility for right of way access restrictions and permissions. Areas of concern should include environmental requirements, crane matting areas, no-go areas and archeological sensitive areas. Contractors must also be aware of right-of-ways that require private permissions and whether the contractor is responsible for getting these permissions. In some instances, the contractor may be required to use specialized type of equipment such as flex track equipment. The contractor should review all access with the above concerns in mind to determine the time and expense necessary to get to the structures before bidding the work.

The contractor must check with the utility for any work hours and work day restrictions, and upcoming utility work that may impact the contractor's schedule.

The chain saws used should be easily handled in the air and powerful enough to plunge cut. The Husqvarna 346XP is a good example of the size saw needed to do this work. The work will be done, usually, off road and it is a good idea to bring backup tools in the event of a tool failure.



Safety Procedures for Tool Operation

Before using the equipment or tools, read Operation and Safety Instructions. Persons not properly trained in its' use must not operate the equipment or tools.

Hydraulic Lifting Unit and Cylinders

The PhaseRaiser® Lifting System is designed for lifting single or two pole wood tangent structures. Any other use of the PhaseRaiser® lifting unit without Laminated Wood Systems, Inc. written approval is prohibited.

- Maximum lifting load capacity using two cylinders: 11,000 pounds working load (with a 4:1 safety factor)
- Maximum lifting load capacity using four cylinders: 22,000 pounds working load (with a 4:1 safety factor)
- Two cylinders must be used for all single pole tangent applications.
- Four cylinders must be used for all H-frame and K-frame applications.
- All hoses must be inspected before each use for wear or abrasion.
- Any hoses that appear worn or abraded must be replaced before use.
- Always check all fittings for leaks.
- Keep fittings clean and free from dirt and sand.
- Before any lift, always secure structure using approved safety tension straps.
- Check fluid levels daily.

Utility or Contractor Furnished Tools

- Chain saw(s), (18" bar recommended)
- Plastic or wooden splitting wedges (two minimum)
- Drill(s), (electric, gas, or hydraulic)
- 1" x 18" ship auger bits
- Digger truck capable of lifting 900 pounds
- Service bucket or bucket truck (optional)
- Standard hand tools (typical lineman belt tools)





Installation and Equipment Operation Guidelines

Please take the time to read through these operation and maintenance tips about the trailer, hydraulic lifting unit, cylinders, driving tools and other supplied equipment. *All personnel operating or working around the trailer should be given this information to review prior to operation.*

For questions concerning the operation or safety of the equipment, please call Laminated Wood Systems, Inc. at 1-800-949-3526. Hours 8:00 a.m. to 5:00 p.m. Central Time.

Safety Instructions



**READ THESE INSTRUCTIONS CAREFULLY.
FAILURE TO FOLLOW THESE INSTRUCTIONS
MAY RESULT IN SEVERE PERSONAL INJURY.**

General Safety Considerations

Eye Injury Hazard

All personnel in, on or around the equipment should wear proper safety glasses or goggles. Failure to do so can result in severe eye injury or blindness. Always wear safety glasses with side shields that conform to ANSI Standard Z87.1.

Head Injury Hazard

All personnel in, on or around the equipment or installation sight must wear a protective cap or hat that meets current ANSI Standard Z89.1 – Type 1 Class E.

Cut Hazard

Handling steel units, banding material or any hardware could result in cut hands or fingers. Always wear protective gloves.

Fall Hazard

All personnel working on any of the climbing apparatus used for installation or maintenance of the PhaseRaiser® system should wear proper safety and climbing equipment. Operating any equipment or tool without proper safety equipment can result in a fall.

Equipment and Tool care

Take good care of the equipment and tools. Inspect all equipment and tools prior to use. Keep tools and equipment properly lubricated and clean. Replace any worn or broken parts.

Training

Only trained personnel must operate all equipment and tools. Be certain you receive proper training from your employer. If you have any questions contact your Laminated Wood Systems representative.

The “PRH”(non-driven) PhaseRaiser® System

This manual outlines many of the basic steps necessary to lift an H-Frame structure with the PRH PhaseRaiser® system.

PRH: This system does not require driving into the ground. For this method the pole is cut at 6’-6”. The PhaseRaiser steel members are set level on top of the soil with pairs of cross bolts installed at two locations approximately 4’-6” apart. These cross bolts secure the bottom section of the structure to the steel.

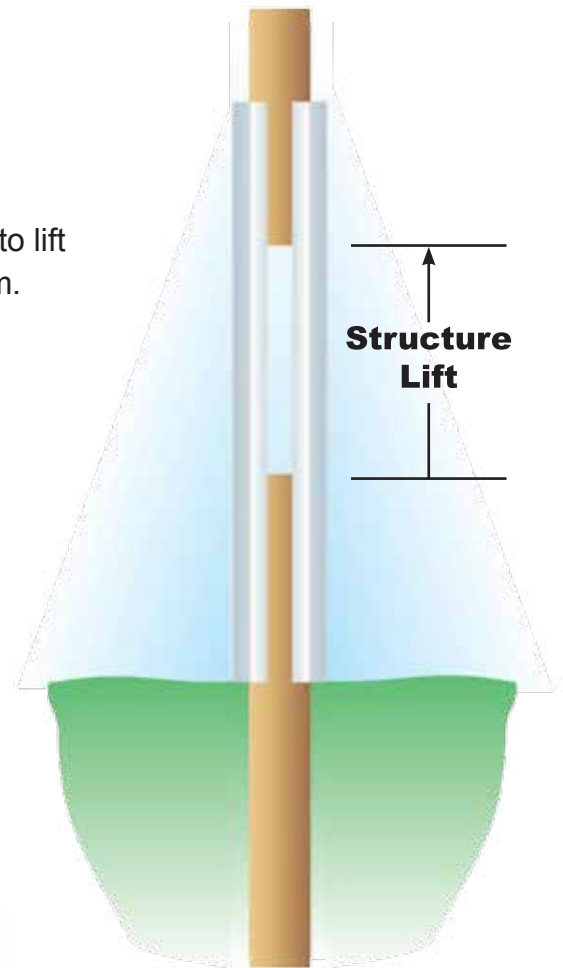

PhaseRaiser® Specialized Equipment Trailer



*NOTE: See Appendix “A”
for detailed equipment
trailer information.*

Important Safety Procedures That Must Be Performed Prior to Raising Structures

Wind Speed

Wind speed should be checked prior to any lift. Unless specified otherwise, no lift should be done if the wind exceeds 25 MPH blowing perpendicular to the line direction. This limit may be increased or decreased for specific applications, but only if authorized in writing by the LWS engineering department.



Review Safety Procedures

A full review of the planned work and all safety procedures should be discussed with all personnel working on or around the structure. When lifting an energized structure, grounding schemes should be discussed and any safety practice the utility chooses should be implemented.



Equipment Placement & Grounding

Position the trailer within 10ft to 15ft of the structure, keeping the trailer as level as possible. Keep an open line of site between the operator's position and the structure. **A determination needs to be made by the utility about the grounding system for the structure and equipment before work starts.**



Install Floating Jumper

A floating jumper can be applied prior to the lift. The floating ground jumper will maintain a structural ground once the existing ground wire is cut. Floating jumper not furnished by LWS (unless requested).



Cut & Relocate Ground Wire

Once the floating ground jumper has been installed, the existing ground wire may be cut.

NOTE: The utility must dictate the grounding method consistent with their safety practices.



Installing the PRH (non-driven) PhaseRaiser® System

STEP 1

When using the “PRH” or non-driven unit, measure up from the groundline 6’-6” and make a visible mark as shown on diagram. Place a leveling rope around the pole at the cut marks. Using a visible marker, draw a level cutting line around the pole.

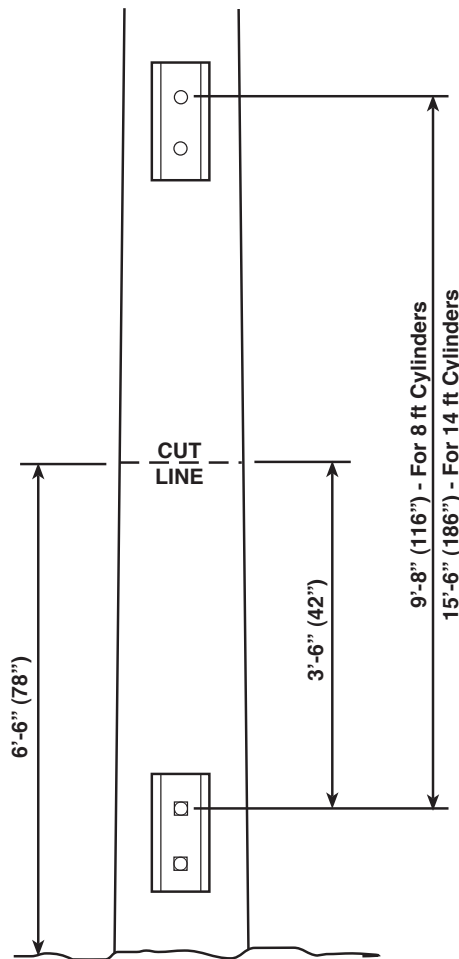

STEP 2

Measure 3’-6” down from the cut line and make a visible mark. This will mark the top hole location of the lower vang.

STEP 3

Position the vang drilling template so the top hole is centered over the mark at 3'-6". The drilling template will need to be visually leveled on both sides. Secure the template to the pole.



STEP 4



Drill vang holes using the alignment tool. **Do not overtighten the tool.** *Lightly position the guide cones in the steel template.*

⚠ WARNING

POLE MUST HAVE 2" MINIMUM SOUND WOOD SHELL AT THIS LOCATION!

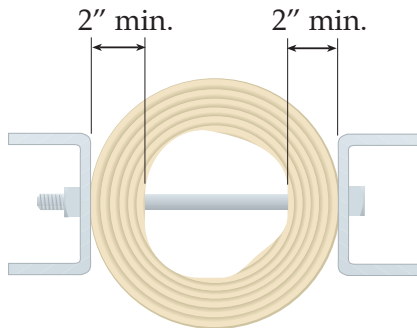

STEP 5



Drill approximately half way from each side. Remove the alignment tool and clean out each hole.

STEP 6

Remove the vang drilling template and mount the bottom set of lifting vangs.



PhaseRaiser® Installation & Tool Equipment Guidelines

STEP 7

Measure the width of the PhaseRaiser steel and mark along the cut line. With a chainsaw make the first cut approximately the depth the steel will cover. **Cut only one side of the pole at a time, just prior to positioning the steel.**

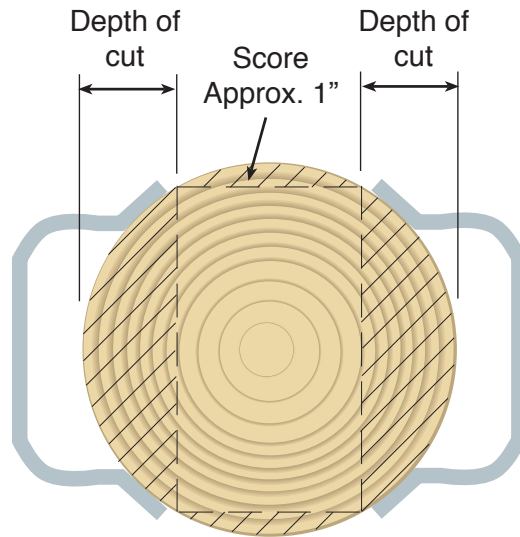

STEP 8

Lift the PhaseRaiser® steel using the furnished lifting hook, making sure the “keeper” pin is engaged and secured with the “detent” pin.

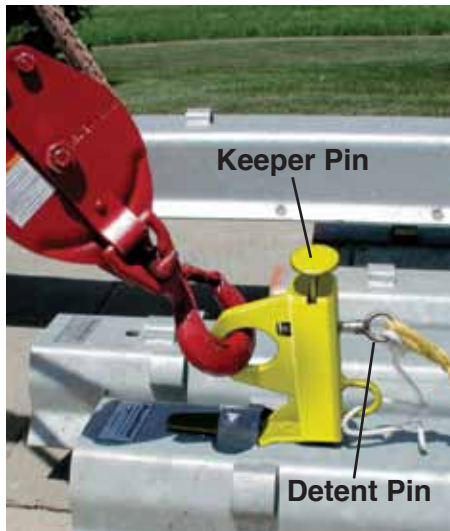

STEP 9

With a line truck or boom truck, position the PhaseRaiser steel over the cut previously made in the pole. Secure the steel in place with a ratchet strap. Remove the lifting hook by pulling on the tag line, then remove tension on the winch line. The lifting hook should then slide out of the pick point.



STEP 10

The second cut can be made following the procedure in step 7. Position the second piece of steel and secure with ratchet straps.



STEP 11

Place a visible mark next to the top hole, 6” below the cut line. Place the second piece of steel so its hole is 9” below the cut line.

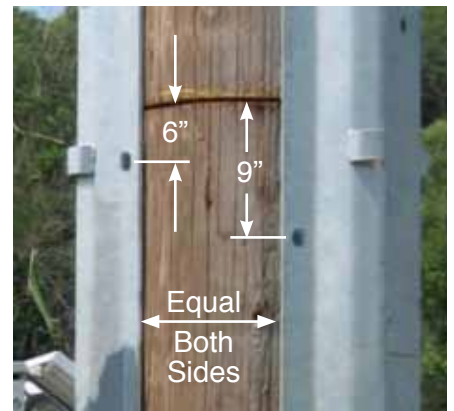

After the second piece of steel is placed, the gap between the edges of the steel should be equal on both sides of the pole.

PhaseRaiser® Installation & Tool Equipment Guidelines

STEP 12 & 13

Use the drilling alignment tool and drill cross bolt holes below the cut line.

Install the cross bolts securing the pole foundation.



STEP 14



The PhaseRaiser® steel members may become part of the grounding system by connecting the ground wires to the cross bolt assemblies at both top and bottom bolt locations after the lift has been completed.

STEP 15

Install the working ladders in the ladder clips.



STEP 16

Measure from top mounting bolt (lower vang) up 9'-8" or 15'-6" as shown in diagram at right. This is the location of the center of the upper vang top hole. Drill vang holes using the same procedure used in steps 4 and 5.

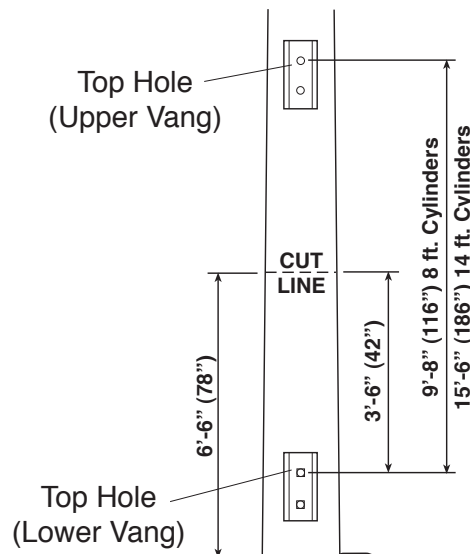

PhaseRaiser® Installation & Tool Equipment Guidelines

STEP 17

Position upper vangs and bolt into place.



STEP 18

Using the nylon ratchet straps, secure the structure in a minimum of two locations.



STEP 19

Using a chainsaw complete the cut through the center section of the pole.

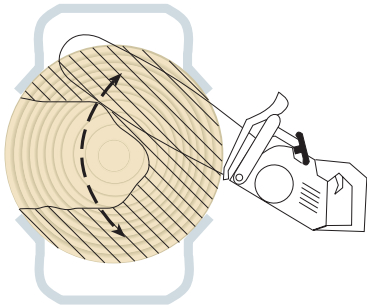

STEP 20

Splitting wedge should be used to keep the saw bar clear. Once the pole is cut completely through, remove the wedge. The pole should move downward.

STEP 21



The pole is cut completely through.

STEP 22

Using the boom truck, the lifting cylinders can be positioned and pinned into the bottom hole of the top vang.

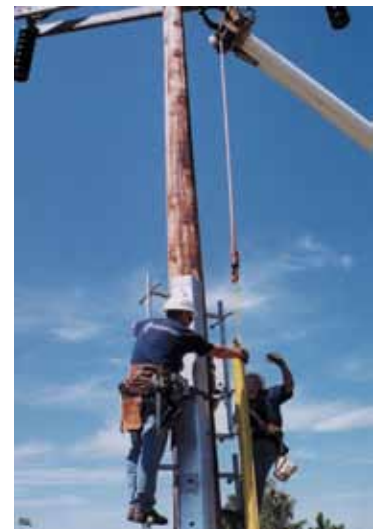

STEP 23

The hydraulic lines can be connected to the cylinders, extended and pinned into the top hole of the bottom vang.

NOTE: See appendix "A" for proper hydraulic hose connection instructions.



STEP 24

CAUTION: Before starting the lift, double check the tension on all ratchet straps. Straps should be "snug" but not "tight" so the structure can move freely. If the straps are too tight the structure will not move and bending or breaking of the hydraulic cylinders may occur.

Start the lift, raising the structure past the second face hole location far enough to pass a 1" safety rod through both pieces of steel. This will act as a safety in the unlikely event that the structure would move downward. Now place the double nutted 7/8" rods through the center of the cut into both sides of the steel. Adjust the inside nuts flush with the steel. Now nut the outside portions of the rod, tighten and secure with a locknut.

IF PERFORMING A LIFT OF 7'-0" OR LESS, PROCEED TO STEP 25



Instructions for multi-stage lifts, 12 to 20 feet.

Raise structure in the standard method. When the raise is at the 10th hole in the face with 9 threaded rods installed and tightened and the safety rod is in the 10th hole position, raise the structure several inches above the safety rod. Then tighten the lower ratchet straps to help secure the structure. Doing one pole at a time, have personnel at both bottom cylinder locations. The trailer operator will move the corresponding cylinder operating lever in the retraction direction. This is a short momentary movement of the control lever. The personnel at each of the bottom cylinder mounting points should feel the cylinders relax enough to pull the bottom mounting pins out of the cylinder plates. At this point the cylinders can be retracted upward until the desired length extension leg can be pinned to the bottom of the cylinder.



PhaseRaiser® Installation & Tool Equipment Guidelines

Lifting 12 to 20 feet - continued

Each Lifting and Equipment trailer is equipped with both 6'-0" and 9'-0" extension legs. The 6'-0" extension legs are used if a maximum lift of 15'-0" is desired. The 9'-0" extension legs are used for a maximum lift of 20'-0".

Continue to retract the cylinders until both are fully closed. Then extend the cylinders and extension legs back downward until both can be pinned in the top holes of the bottom cylinder plate. Once pinned in position use a long threaded rod and insert it through both extension legs in the holes provided. Do not tighten the outer nuts at this point. Remove 2 of the spacer blocks from the trailer tool box and place them between the cylinder extension and the PhaseRaiser steel. The spacer block has a rounded slot in the center, which is placed over the threaded rod. Tighten the 2 outside nuts on the threaded rod securing the extensions. For H-Frame or Multi pole raises, repeat this procedure until all poles have the extensions.

Loosen the ratchet straps that were tightened prior to unpinning the cylinders. Continue with the desired lift height.



STEP 25

Continue the raise and lace the remaining treaded rods using the same procedure as in step 24.



STEP 26

Using the drilling alignment tool, drill the upper cross bolt holes.



STEP 27



Install the 7/8" cross bolts in both upper cross bolt locations.

STEP 28

The PhaseRaiser® steel members may become part of the grounding system by connecting the ground wires to the cross bolt assemblies at both top and bottom bolt locations after the lift has been completed.



STEP 29

After the cross bolts have been installed and tightened at each location, the lifting cylinders can be removed and stored back on the PhaseRaiser equipment trailer.



STEP 30

After removing the cylinder vangs, the bolt holes should be treated and plugged with 1-1/8" treated dowels.



STEP 31

The safety caps can be installed after the cylinders are removed. Ring shank nails are included with each cap.



STEP 32

Apply approximately 1/4" to 1/2" of treatment to the exposed pole butt. This can be applied with a stiff brush or wooden paint stick. Rubber gloves should be worn to minimize skin exposure. The treatment is water soluble and does not require an applicator license to apply.



PhaseRaiser® Installation & Tool Equipment Guidelines

STEP 33

A tar paper cover should be placed over the treated area.



STEP 34

Install anti-split bolts near cut sections per LWS drawing.



STEP 35

The side shields can be positioned and nailed into place.



STEP 36

An optional galvanized 3/4" band can be placed around the side shield to secure the center from high winds. This is recommended on lifts of 10'-0" or more.



COMPLETED LIFT

APPENDIX "A"



Equipment Trailer Operator's Manual



Laminated Wood Systems, Inc.

1327 285th Road • Seward, Nebraska 68434 • 800-949-3526 • www.lwsinc.com

THIS PAGE INTENTIONALLY LEFT BLANK

Table of Contents

Safety Notices	A4
Trailer Specifications	A6
Operating Instructions	A7
Hydraulic Cylinder Capacities.....	A10
Tooling	A11
Maintenance	A13
Troubleshooting.....	A14
Hydraulic Schematic.....	A15
Electrical Schematic.....	A16

Important Safety Notices



Attention PhaseRaiser Crews

THE FOLLOWING PROCEDURES MUST BE FOLLOWED TO INSURE WORKER SAFETY AND PROPER OPERATION OF THIS EQUIPMENT TRAILER

1. Check all fluids daily - Engine Oil, Hydraulic Oil, and Fuel.
2. Check all hydraulic hoses and fittings. Leaking fittings need to be replaced prior to use.
3. Do not alter or modify any equipment or furnished tools without permission from Laminated Wood Systems, Inc.
4. Never disconnect hydraulic lines under pressure. Always turn the engine off then move each control back and forth prior to disconnecting fittings.
5. Operator must have a clear line of sight to the structure being raised and should have constant communication with the personnel on the structure.
6. Hydraulic Cylinders must be straight and plumb when mounted on the structure. Failure to do so may cause permanent damage to the cylinders and the structure.
7. Only qualified personnel may operate this equipment.
8. Personnel working at or around the work area must wear proper safety equipment including hard hat, safety glasses, work boots and gloves.
9. Personnel working above ground level must wear proper climbing equipment.
10. Working ladders must be inspected before each use. Loose steps need to be tightened before being placed on the structure. Bent and broken ladders need to be replaced. The use of damaged or broken ladders could result in a fall causing serious injury or death.
11. Any damage repairs to the trailer, trailer equipment and contents other than what is deemed daily use, are the responsibility of the user.
12. All personnel operating the equipment must be properly trained by Laminated Wood Systems personnel. Operating the equipment for any use other than what it was designed for may result in serious injury or death.
13. It is the responsibility of the utility or contractor to implement proper work and safety methods. Laminated Wood Systems, Inc. is not responsible for daily work safety practices.
14. Any questions should be directed to Laminated Wood Systems, Inc. at 800-949-3526.

Trailer Safety Features

The LWS PhaseRaiser trailers are all equipped with check valves located in the base of each cylinder. In the unlikely event of a catastrophic hose or system plumbing failure the cylinders will not retract until hydraulic pressure is restored.

A ground stirrup is installed on all trailers and clearly marked.

Caution and Warning signs are displayed clearly in locations to be easily seen.



Each PhaseRaiser trailer has the hydraulic capacity to lift or move up to 88,000 pounds of weight using 4 cylinders and 44,000 pounds of weight using only two cylinders. Per National Safety Standards the lift rating is 22,000 pounds. (4 to 1 Safety Factor)

Each piece of equipment is designed to perform safely if operated within the equipment rating.

Safety is our main priority.

! CAUTION !

ONLY TRAINED, QUALIFIED PERSONNEL MAY OPERATE THIS EQUIPMENT.

PERSONNEL WORKING AT OR AROUND THE WORK AREA MUST WEAR PROPER SAFETY EQUIPMENT INCLUDING HARD HAT, SAFETY GLASSES, WORK BOOTS AND GLOVES.

IT IS THE RESPONSIBILITY OF THE UTILITY OR CONTRACTOR TO IMPLEMENT PROPER WORK AND SAFETY METHODS.

LAMINATED WOOD SYSTEMS, INC. IS NOT RESPONSIBLE FOR DAILY WORK SAFETY PRACTICES.

Trailer Specifications

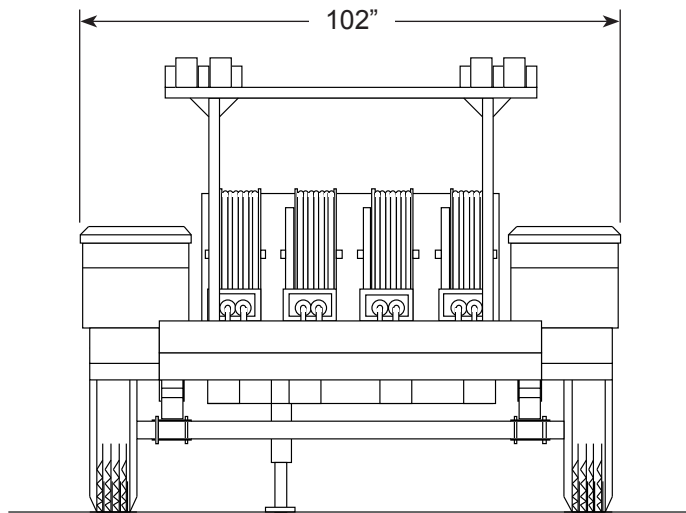
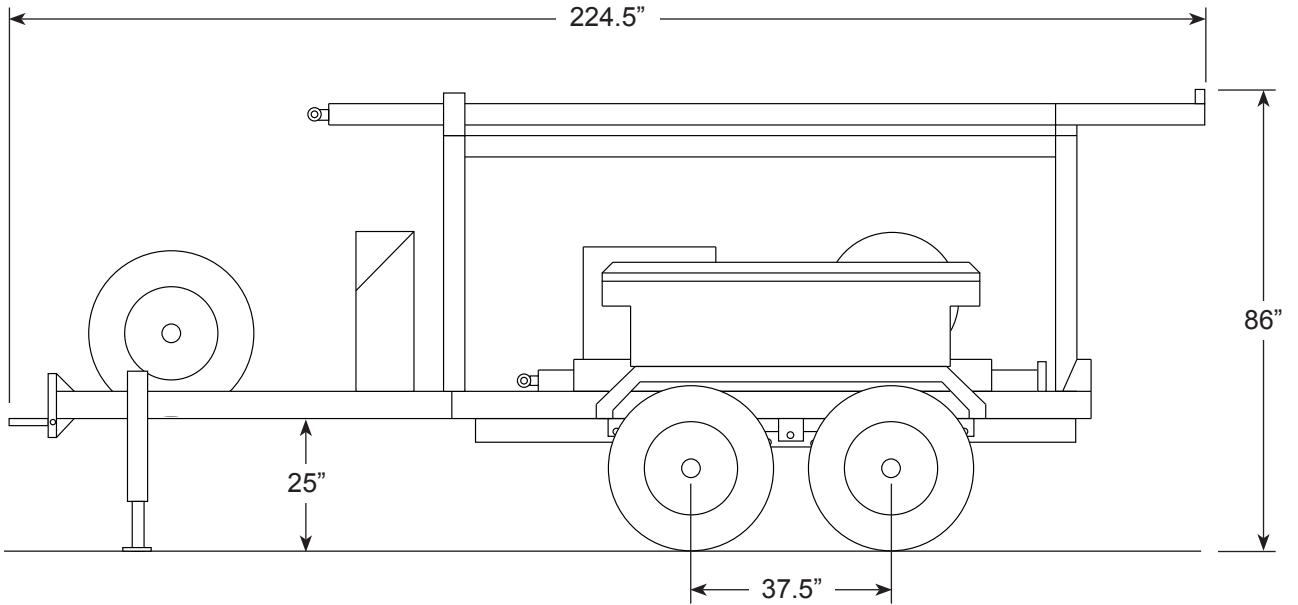

Gross vehicle weight 9,000 lbs.
 Max axle capacity 7,000 lbs. per axle
 Rim size 16"
 Tire size LT235/85R16
 Tire pressure 80 psi
 Hydraulic oil reservoir capacity 65 gallons

Hydraulic oil type 5W20 Multiviscosity
 (Cold climate oil recommendation:
 Hyken Glacial Blue or Artic Blue oils)
 Engine type Gasoline
 Gasoline tank capacity 10 gallons
 Electrical system 12 volt
 Brake system Drum

Operating Instructions

This section makes the assumption that the structure has been prepared and the hydraulic cylinders have been installed on the poles per the instructions in the PhaseRaiser® Field Installation Manual.

Hydraulic Hose Connection

Connect the hydraulic hoses to match the color of the hose reel to the cylinders, red to red & green to green as shown in the diagram at Right. 

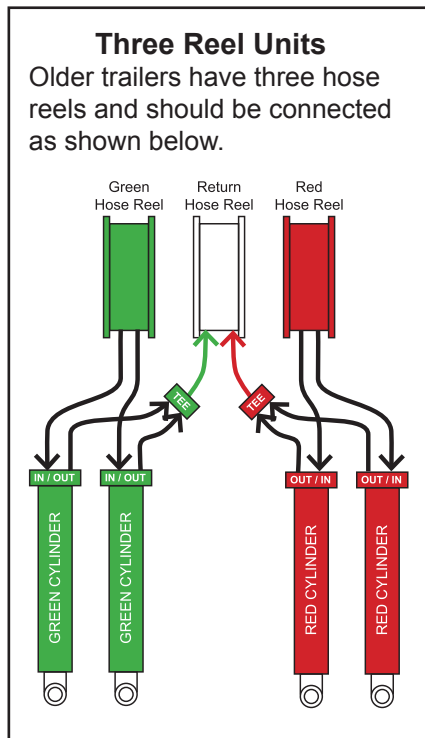

Four Reel Units

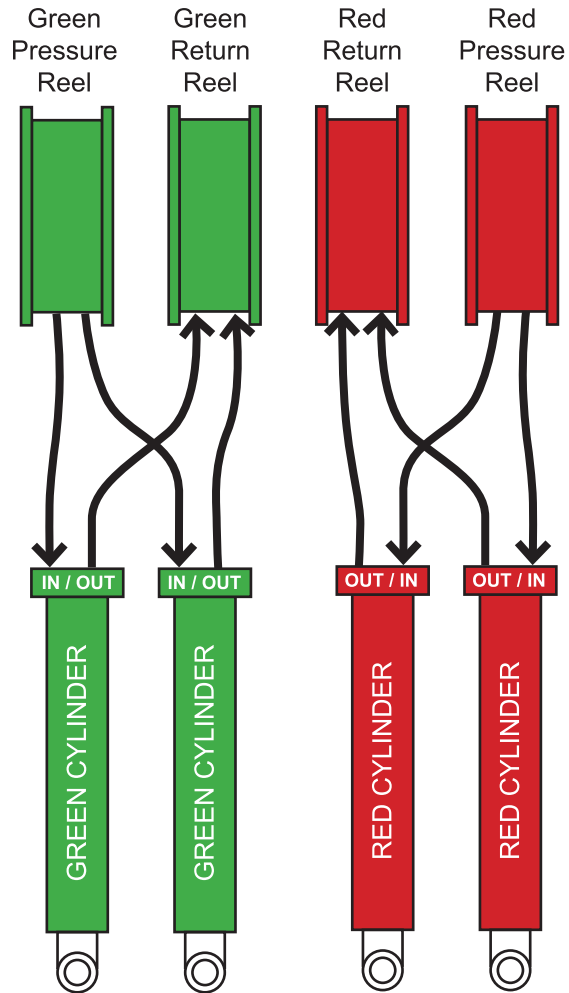

Cylinder Operation

Start the trailer engine (choking may be required) and allow engine to run at idle for at least one minute. This will allow the engine and hydraulic oil to warm up to operating temperature.

Increase throttle to a high enough RPM so that the engine does not bog down when cylinders are actuated. Move valve control levers "down" to extend cylinders, and "up" to retract cylinders.

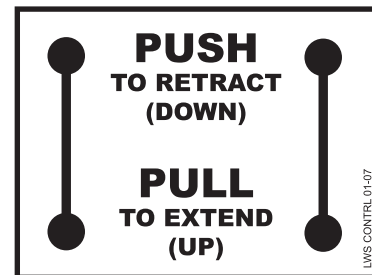

Operating Instructions - Continued

Hydraulic Hose Connections:

With cylinders mounted in the upper vang or cylinder plate begin connecting the hydraulic hoses. The connectors are arranged to make it extremely difficult to make a wrong connection. There are 4 hydraulic hose reels mounted on the rear of the trailer platform. Two Red, Two Green.

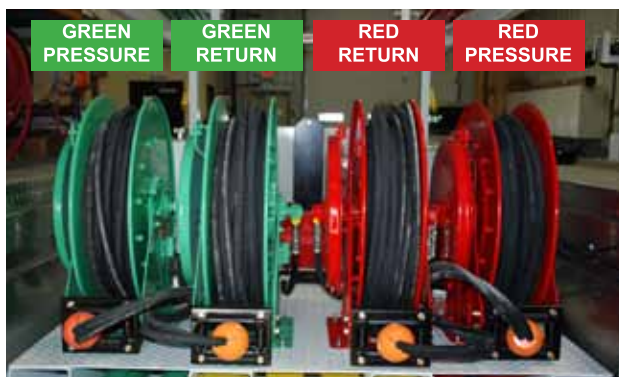

The outer Red & Green hose reels are the pressure reels and their hoses have male connectors. The inner Red & Green hose reels are the return reels and their hoses have female connectors. Connect the matching red & green hoses to the corresponding fittings on the red & green cylinders.

Since each pair of cylinders can be operated independent of each other, start the trailer engine and adjust the RPM speed. Extend each pair one set at a time in order to secure the cylinders in the top pin hole of the lower vang or cylinder plate. Repeat this procedure for the opposite pair of cylinders. You are now ready to make a structure lift. If the structure being raised is a single pole structure only one pair of cylinders is needed. See connection diagram.

Disconnecting Hoses after the Lift is Complete:

At no time should any of the hydraulic hoses be disconnected while the system is under pressure. When the structure is raised and fully secure, the cylinders can now be removed. This should be done one pair at a time. Start engine and adjust engine RPM. With personnel in position at each lower mounting point, move operating valve to relieve pressure enough to remove each of the cylinder mounting pins. Once the pins are removed and cylinders are free to move, retract the cylinders to the completely closed position. Once this is completed, shut the engine off and move the operating valve back and forth to relieve pressure in the hydraulic lines. Now the hoses can be disconnected from the cylinders. This procedure insures the cylinders should remain in time and there is no pressure existing in the hydraulic hoses. If this procedure is not followed, reconnecting hoses is almost impossible without relieving pressure by removing the hose connector. Extra caution should be taken if any connection is loosened or removed while pressure is present. Hot oil can be sprayed as the pressure is relieved from the hose. LWS does not recommend this procedure be performed by personnel who are not familiar with high

pressure hydraulic systems and strongly recommend the trailer is taken to a qualified mechanic an performed in a controlled area.

Cold Weather Operation Procedure:

Prior to lift the trailer should be started and run at an idle speed for a minimum of 5 minutes to allow the oil warm up.

The oil in the cylinders will remain cold until the lift procedure begins. The cylinders will have a tendency to operate slower until the oil temperature warms. Do not run the engine at full throttle, find an RPM range where the cylinders operate without bogging the engine and operate the cylinders smoothly. Operating at very high engine RPM will overheat the system oil, causing the cylinders to lose lifting efficiency while causing the oil to foam, creating air in the system.

Running the engine RPM higher does not increase the speed of cylinder movement. The system is designed to operate at the same rate regardless of engine RPM.

Warm Weather Operation Procedure:

Start engine and allow it to idle for a period of 2 to 3 minutes then proceed with the lift. Check all fittings before and after lift is complete for any leaks. This occurs more frequently in hot weather.

Operating Trailer on hilly or uneven terrain:

Try to position trailer in a location where it can set as level as possible.

Check all fluids each morning prior to beginning the work. Check in this manual for oil types.

Please call LWS at 800-949-3526 before making any modifications to the PhaseRaiser® Trailer or its contents.

Hydraulic Cylinder Capacities & Specifications

CAUTION
 OVER-EXTENDING
 CYLINDERS CAN
 CAUSE PERMANENT
 DAMAGE

8' Cylinder

Cylinder retracted length 104"
 Operating stroke MAX 72"
 Maximum capacity 11,000 lbs per pair

**MAXIMUM
 WORKING
 STROKE ON 8'
 CYLINDERS:
 6 FT.**

8 ft Cylinder

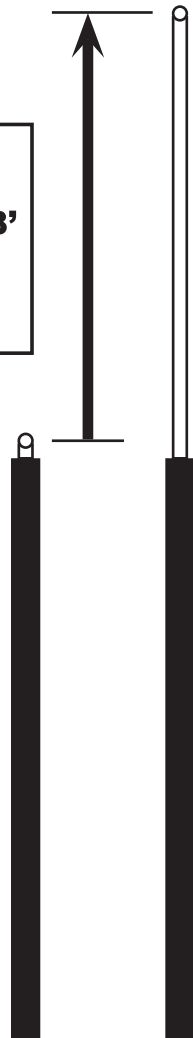

14' Cylinder

Cylinder retracted length 167"
 Operating stroke MAX 120"
 Maximum capacity 11,000 lbs per pair

**MAXIMUM
 WORKING
 STROKE ON 14'
 CYLINDERS:
 10 FT.**

14 ft Cylinder

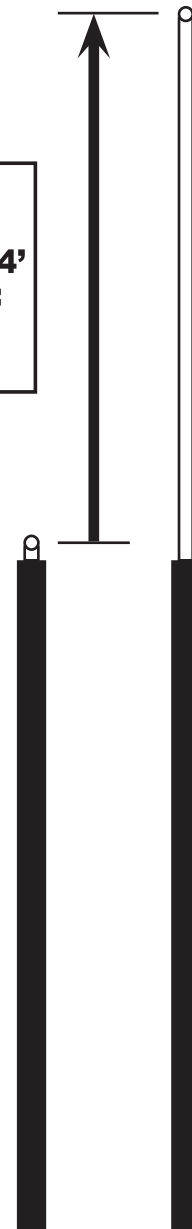

Toolbox Contents

Every new PhaseRaiser® Equipment Trailer is stocked with the tools necessary to perform structure lifts in the field. Over time the custom tools may wear out or get lost. Below is a list of the tools that are required to fully equip the trailer for structure lifting.

PhaseRaiser® Trailer Tool List

TOOL DESCRIPTION	QUANTITY
Lifting Vangs	8
Cylinder Pins.....	12
Quick Release Lifting Hook w/ Rope	1
2" Ratchet Binding Straps	10
1" Safety Rods	2
Drilling Alignment Tools	2
Cylinder Extension Spacer Blocks	4
7/8" x 42" Threaded Rod (used with spacer blocks).....	2
7/8" Square Nut Deep Socket Tool.....	1
Vang Drilling Template Set (2).....	2
3/4" Manual Tensioner	1
Manual Seal Crimper	1

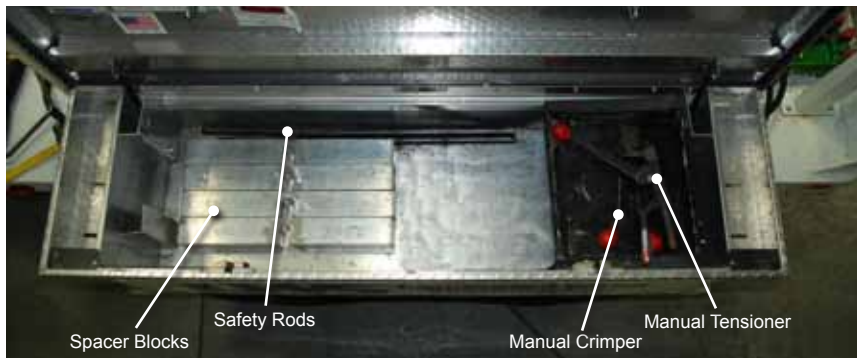
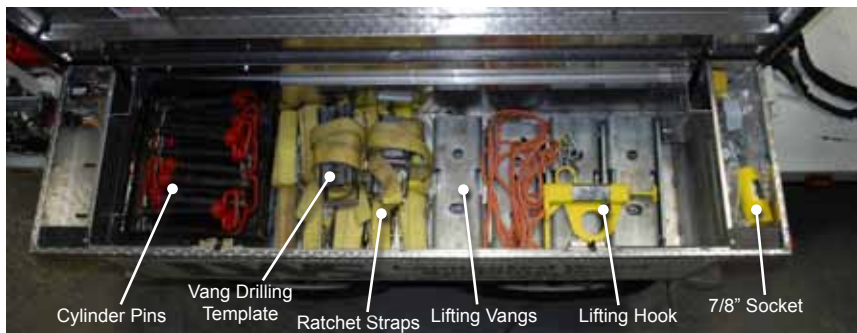

NOTE: Drilling Alignment Tools are stored in the drilling alignment tool box.

Toolbox Contents



Lifting Vang (8 qty)



Cylinder Pin (12 qty)

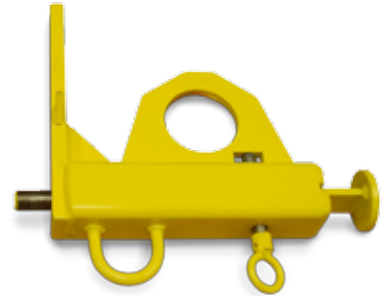

Lifting Vang (1 qty)



Ratchet Strap (10 qty)



Safety Rod (2 qty)



Drilling Alignment Tool (2 qty)



Spacer Block (4 qty)



7/8" x 42" Threaded Rod (2 qty)



7/8" Deep Socket (1 qty)

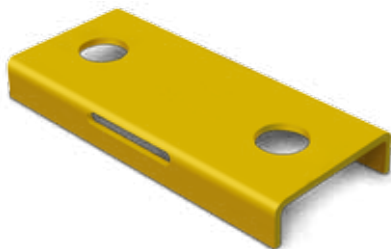

Vang Drilling Template (4 qty)



Manual Tensioner (1 qty)



Manual Crimper (1 qty)

Maintenance

To insure the proper operation and performance of the PhaseRaiser® equipment trailer components, it is important to follow the recommended regular maintenance procedures outlined in this section.

Frequency	Maintenance Required
Daily	<ul style="list-style-type: none">• Fill fuel tank• Check engine oil level• Check hydraulic oil level• Check tire pressure (80 psi recommended)• Inspect hydraulic hose jackets for abrasions, cracks or tears• Inspect hose fittings for collar movement• Clean hose fittings of all dirt & debris• Check electrical connections - brake, turn and running lights
Weekly	<ul style="list-style-type: none">• Test electric trailer brake and break-away pin
40 Hours	<ul style="list-style-type: none">• Change engine oil & filter (SAE 30)• Clean engine air filter

Koehler Gasoline Engine

Refer to the Koehler engine manual that is included with the trailer for specific maintenance and trouble shooting instructions.

Trailer Troubleshooting Guide

Symptoms:

Engine will not start.

Check battery, charge if necessary.

Check battery terminals for corrosion, reinstall.

Check fuel level

If the issue is engine related see engine manual supplied with trailer.

If the issue is electrical please refer to the electrical schematic enclosed.

Trouble Shooting the Hydraulic System:

Cylinders Operate Slow or Erratic.

Most probable cause: Air has entered the system. Check the oil inside the hydraulic oil tank reservoir.

If the oil appears foamy air has entered the system. Most air can be purged by laying the cylinders out on the fairly level ground and extending them to full rod out then retracting to full close several times for each pair. Make sure the engine RPM is at the lowest possible speed but will still operate the cylinders without bogging or killing the engine. See trailer operation and connection diagram. Check oil level in reservoir, low oil level can create air in the system.

Cylinders Will Not Operate.

Shut the trailer off and call LWS for technical assistance.

Hydraulic Schematic Diagrams

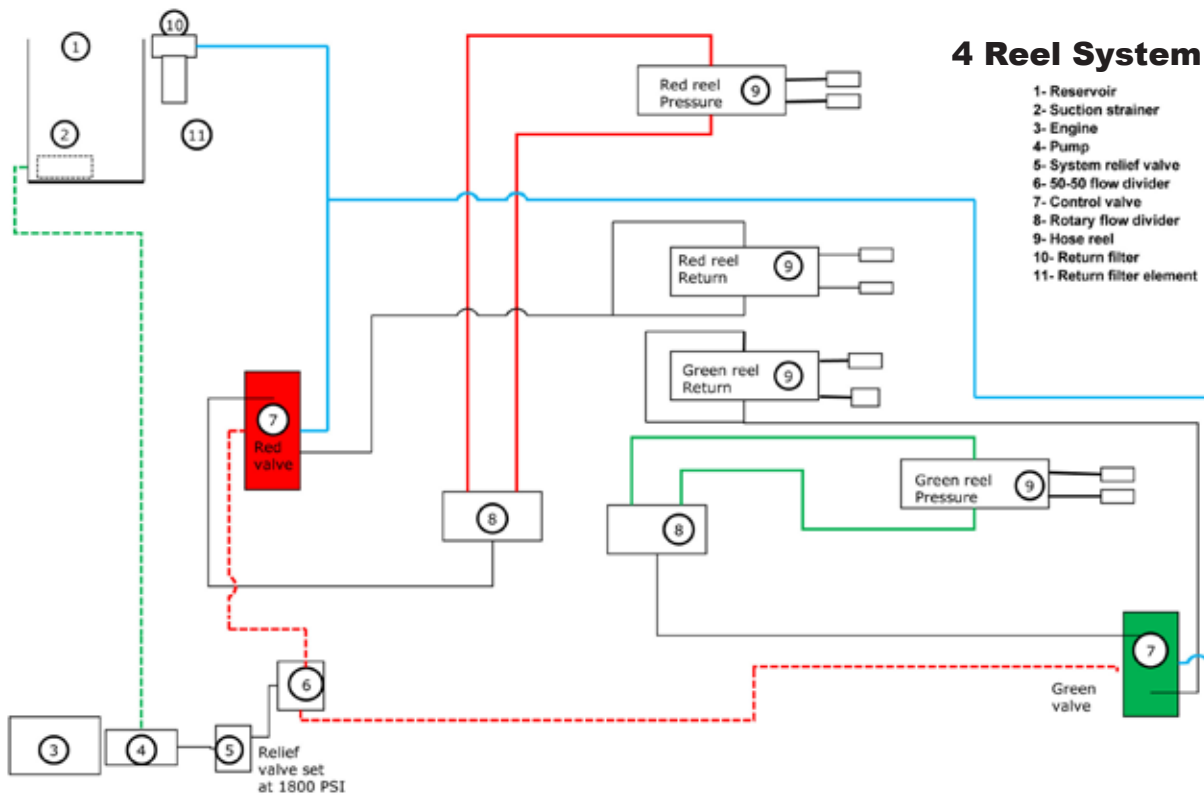
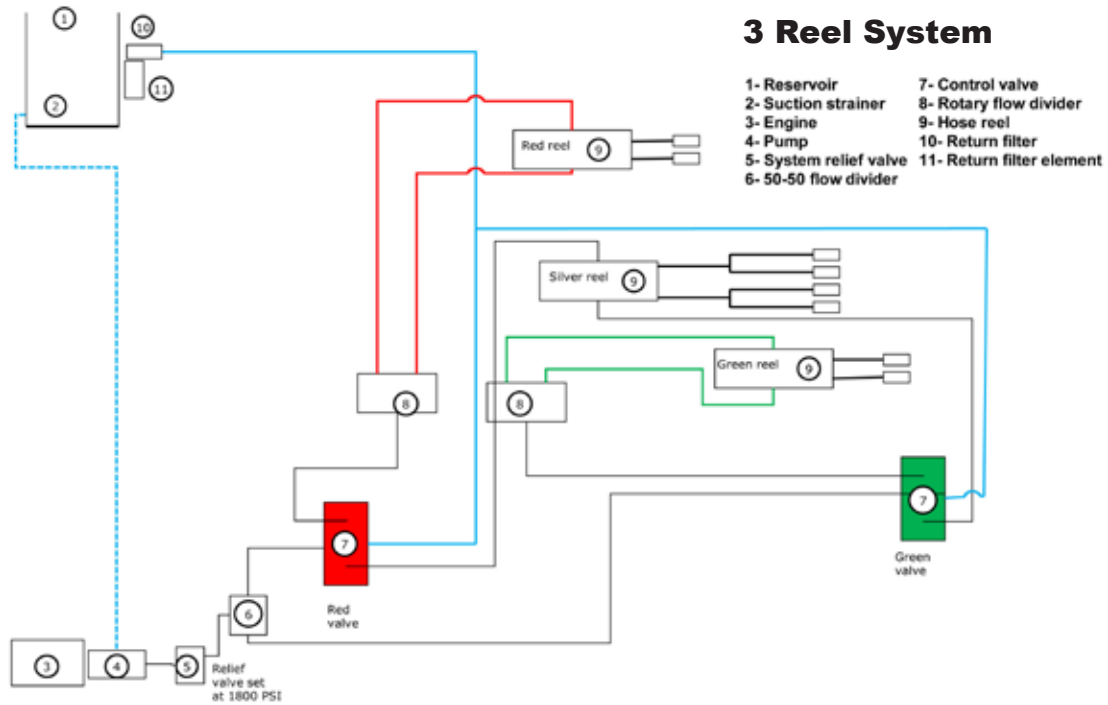

Electrical Schematic

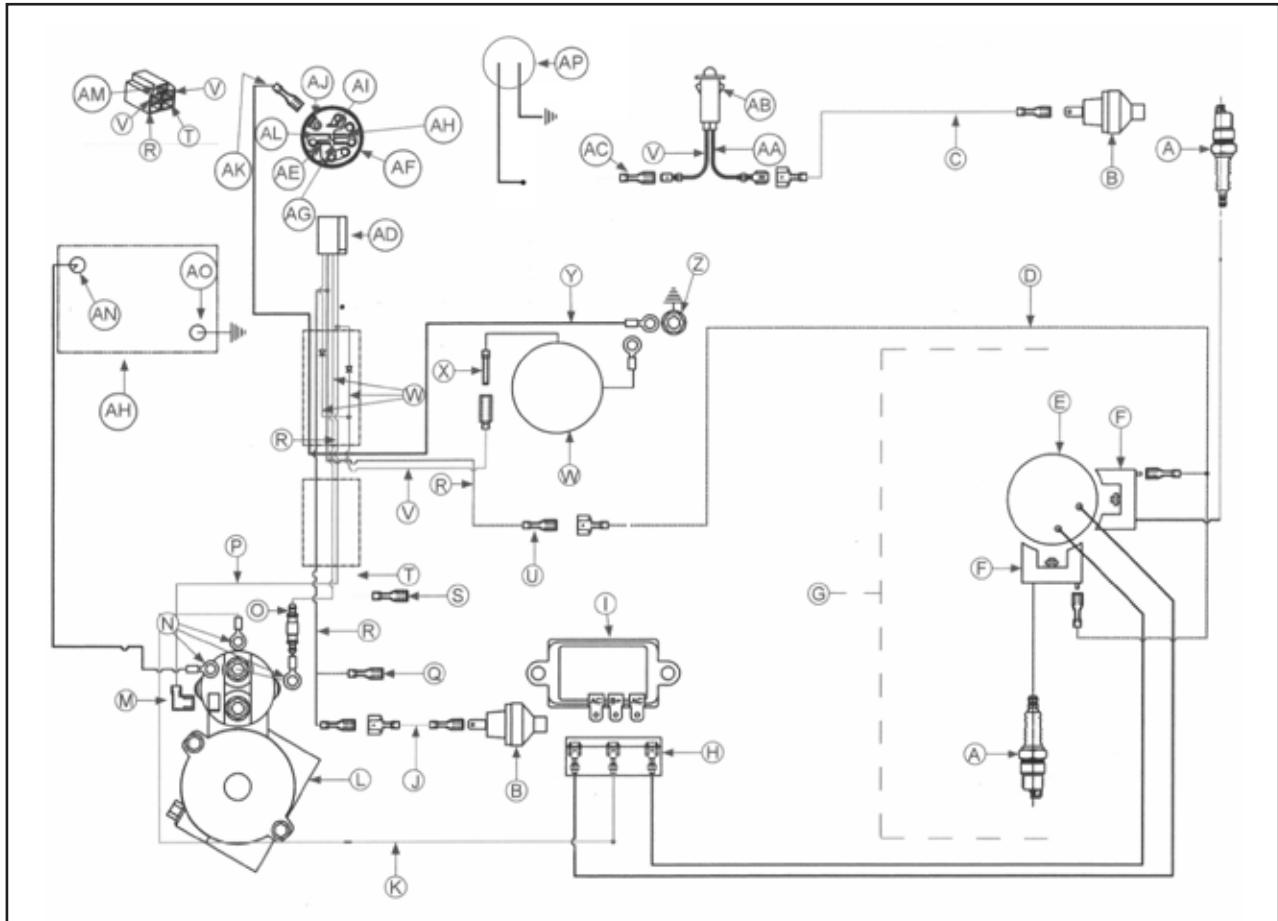

Fixed Ignition System - This system uses a captive discharge (CD) coil. Ignition timing and spark remains constant regardless of engine speed. Timing of spark is controlled by location of flywheel magnet group as referenced to engine TDC. A typical fixed ignition system consists of:

- 1 magnet assembly which is permanently affixed to flywheel
- 2 electronic capacitive-discharge ignition modules which mount on engine crankcase
- 1 kill switch (or key switch) which grounds modules to stop engine
- 2 spark plugs

A	Spark Plug(s)	B	Oil Pressure Switch	C	Oil Sentry (Green)	D	White Kill
E	Flywheel Stator Assembly	F	Ignition Module	G	Non-Smart Spark Ignition	H	Rectifier-Regulator Connector
I	Rectifier-Regulator	J	Oil Sentry Kill (Green)	K	Violet B+	L	Solenoid Shift Starter Assembly
M	Starter Solenoid Tang	N	Starter Solenoid Stud	O	Fuse	P	Blue
Q	Alternate Ignition Kill (-)	R	White	S	Accessory Terminal (+)	T	Yellow
U	Ignition Kill	V	Red	W	Carburetor	X	Carburetor Solenoid
Y	Black (Ground)	Z	Intake Manifold Screw	AA	Black	AB	Oil Sentry Panel Light/Remote Light
AC	Oil Sentry Light	AD	Connector	AE	Magneto	AF	Key Switch
AG	Accessory	AH	Battery	AI	Starter	AJ	Ground
AK	Key Switch Ground	AL	Rectifier	AM	Blue/Red	AN	Battery Positive
AO	Battery Negative	AP	Hour Meter				